

Marking Instructions	
<ul style="list-style-type: none"> • Use a No. 2 pencil or a blue or black ink pen only. • Do not use pens with ink that soaks through the paper. • Make solid marks that fill the response completely. • Make no stray marks on this form. 	<p>CORRECT: ●</p> <p>INCORRECT: ○ ⊗ ⊙ ⊖</p>

Name: _____ Date: _____

For each question below, fill in the bubble for the **BEST** answer.

1. The figures below show a light bulb connected to a battery in two different ways. When the switch in Figure 1 is closed, the bulb will light. What will happen when the switch is closed in Figure 2?

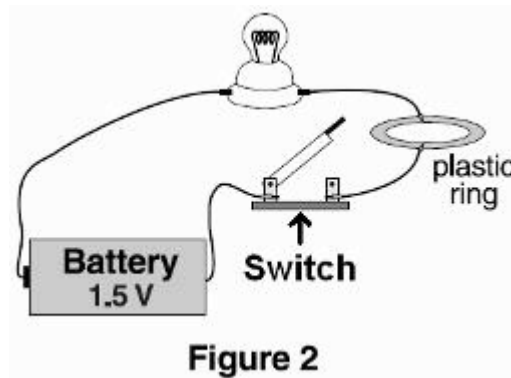
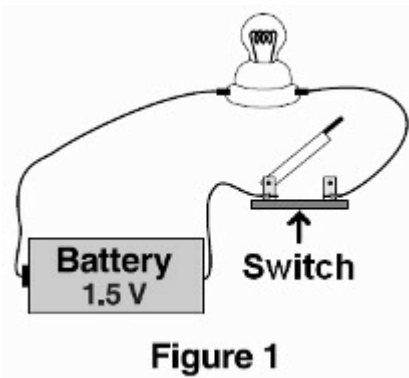

- Ⓐ The bulb will light just as it did in Figure 1.
- Ⓑ The bulb will be brighter than it was in Figure 1.
- Ⓒ The bulb will light, but it will be less bright than it was in Figure 1.
- Ⓓ The bulb will not light at all.

2. Which picture shows a circuit that will cause the bulb to light up?

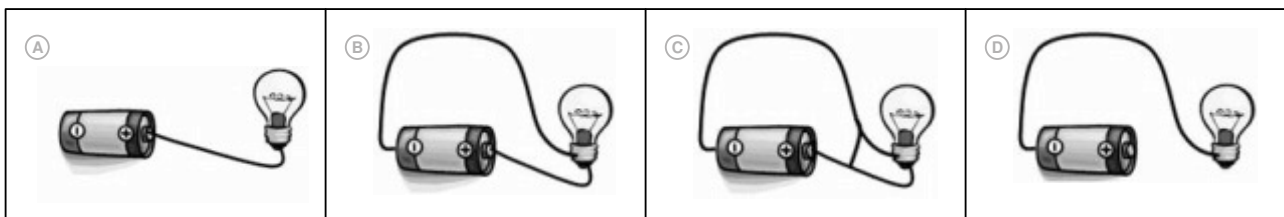

PLEASE DO NOT WRITE IN THIS AREA



[SERIAL]

3. The picture to the right shows two bulbs and a switch in a circuit.
Which of the bulbs can be turned on and off by the switch?

- Ⓐ bulb 1
- Ⓑ bulb 2
- Ⓒ both bulbs
- Ⓓ neither bulb

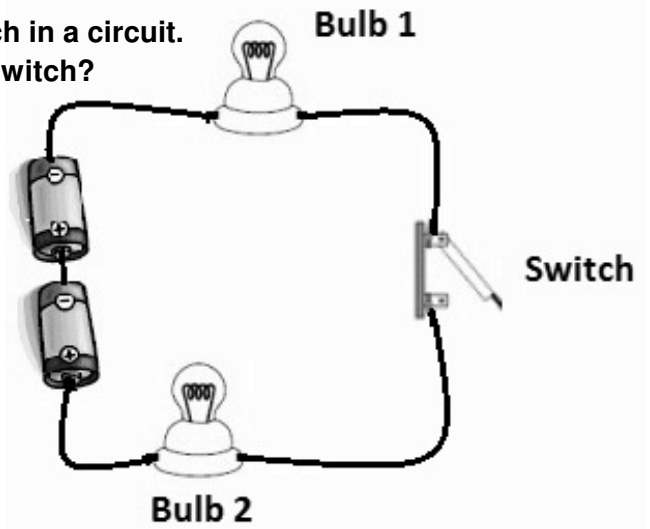

4. Which set of parts could you replace with wire in the circuit below? You should still have a safe and complete circuit.

- Ⓐ battery and bulb
- Ⓑ battery and buzzer
- Ⓒ switch and bulb
- Ⓓ switch, bulb, and buzzer

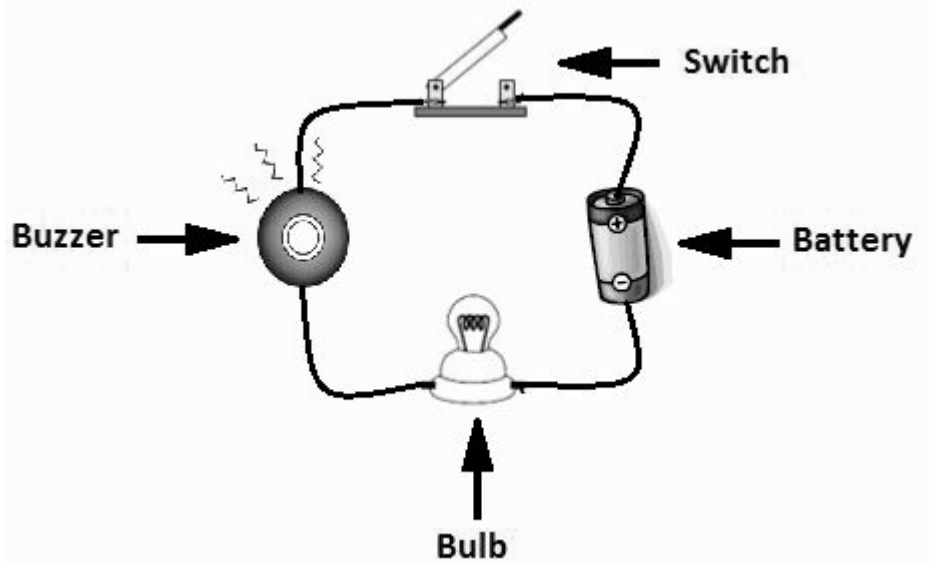

5. The picture to the right shows two bulbs and a switch in a circuit.
Which of the bulbs can be turned on and off by the switch?

- Ⓐ bulb 1
- Ⓑ bulb 2
- Ⓒ both bulbs
- Ⓓ neither bulb

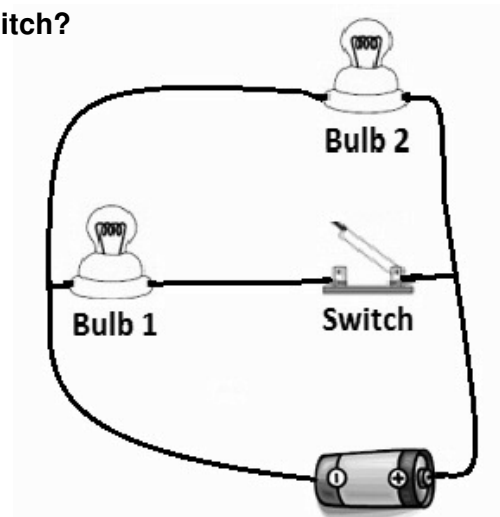

6. In which circuit below will both bulbs light?

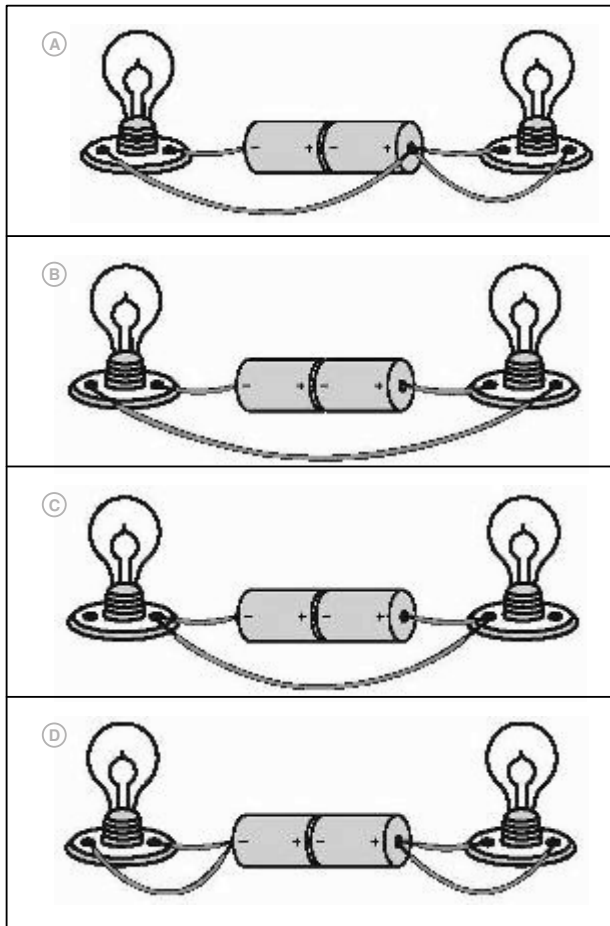

7. The picture below shows two bulbs and a switch in a circuit. Which of the bulbs can be turned on and off by the switch?

- (A) bulb 1
- (B) bulb 2
- (C) both bulbs
- (D) neither bulb

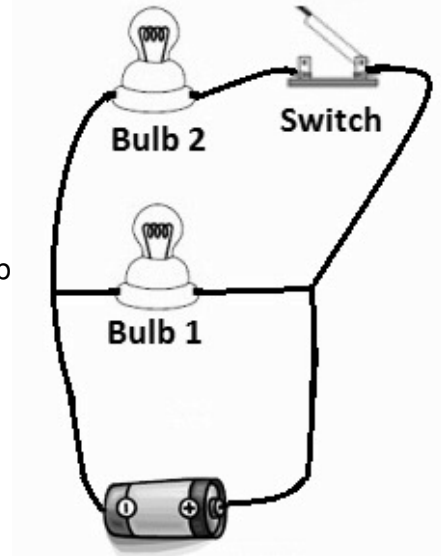

8. The picture to the right shows a glowing light bulb connected to a battery using wires. An electric current is flowing from the battery, through Wire #1, to the bulb.

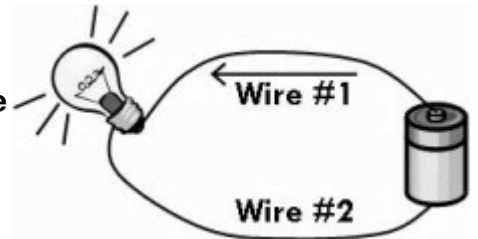

What is happening in Wire #2?

<p>(A) The electricity flows through Wire #2 from the battery to the bulb.</p>		<p>(C) The electricity flows through Wire #2 away from the bulb to the battery.</p>	
<p>(B) No electricity flows in Wire #2, it is all used up by the bulb.</p>		<p>(D) Electricity flows both ways through Wire #2, from the battery to the bulb and back again.</p>	

The picture below shows three light bulbs in a circuit. Use the picture to answer questions 9 and 10.

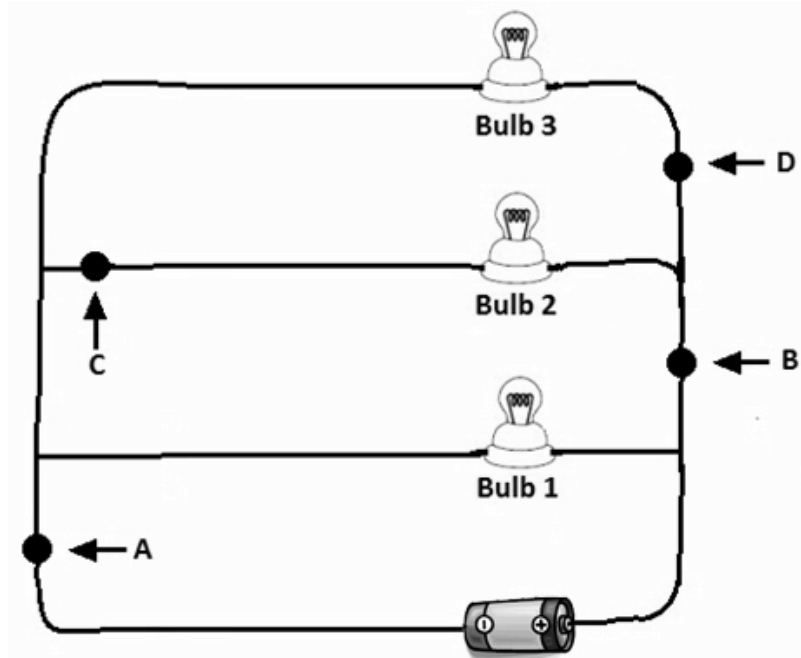

9. Where should you put a switch so that bulb 2 and bulb 3 can be switched on and off, but bulb 1 will stay on all the time?

- A location A
- B location B
- C location C
- D location D

10. Where should you put a switch so that bulb 2 can be turned on and off, but bulb 1 and bulb 3 will remain on all the time?

- A location A
- B location B
- C location C
- D location D

Question 3 from MCAS 2007 STE Assessment- Gr 5.
Question 4 from MCAS 2003 Science and Technology/Engineering (STE) Assessment - Grade 5. Question 9 from MCAS 2010 STE Assessment- Gr 5.
Massachusetts Department of Elementary and Secondary Education, Boston.

PLEASE DO NOT WRITE IN THIS AREA

[SERIAL]